

KNOWLEDGE SHARING IN LOGISTIC NETWORKS

*Professor PhD Ștefan Nedelea, Academy of Economic Studies of Bucharest, e-mail:
stefan_nedelea@yahoo.com*

*Teaching Assistant PhD Student Laura Adriana Păun, Academy of Economic Studies of Bucharest,
e-mail: laura.paun@mail.com*

ABSTRACT: The pressure of surviving in the new economy forces organizations to interact on multiple levels, making supply chains evolve into logistic networks. In order to achieve the high performance desired, each member of the partnership must give up the opportunistic behaviour and share the critical knowledge it possesses for the benefit of the entire network. This implies a certain amount of trust and equity between partner organizations that requires a significant change in the managerial approach of sharing efforts, information and benefits.

Keywords: Knowledge, coordination, logistic network

JEL Codes: L14, L1

Generally, a supply chain is considered to consist of all parties involved, directly or indirectly, in fulfilling a customer's request. The supply chain includes not only the manufacturer and supplier, but also transporters, warehouses, retailers and even customers themselves. Within each organization, the supply chain includes all functions involved in receiving and filling a customer's request, such as new product development, marketing, operations, distribution, finance and customer service.

Yet, under the pressure of the new economy, no organization can afford anymore to limit its interaction to just a „chain” (defined as a series of stages linked together in a single line) of partners; they now have to evolve into integrated logistic networks and, based on their organizational competence, continuously generate and transfer knowledge inside the network.

The logistic networks are dynamic constructions that require a permanent flow of products, funds and information between their separate stages, including the end customer. In fact, the primary purpose of any logistic network is to satisfy customer needs, and in the process, generate profit for itself.

A typical logistic network may involve a variety of stages (the figure below), such as:

- Customers (C)
- Retailers (R)
- Wholesalers/distributors (D)
- Manufacturers (M)
- Component/raw material suppliers (S)

Each stage of the logistic network is multiply connected with the others not only through the flow of products, funds and information, but also through a complex mechanism of coordination, designed to generate and support trust, which is essential for any knowledge transfer. The lack of coordination leads to a degradation of responsiveness and an increase in cost within the logistic network, which will eventually turn into diminished profitability of the entire network. The network coordination requires that each stage of the logistic network to take into account the impact its actions have on other stages, especially when it comes to generating and transferring knowledge.

Since competences need to change over time in order to maintain its value, the generation of new knowledge and innovation is crucial for both individual organizations and networks. This

innovation process can be distinguished into the exploration and the exploitation phase. The exploration phase leads to new knowledge which is intended to end in radical innovations, while the exploitation phase leads to the appliance of existing knowledge and incremental innovations. These phases are usually consequent: during the exploration phase, a dominant design emerges, after which the level of experimentation drops significantly and exploration turns into exploitation in which the potential of the innovation is explored.

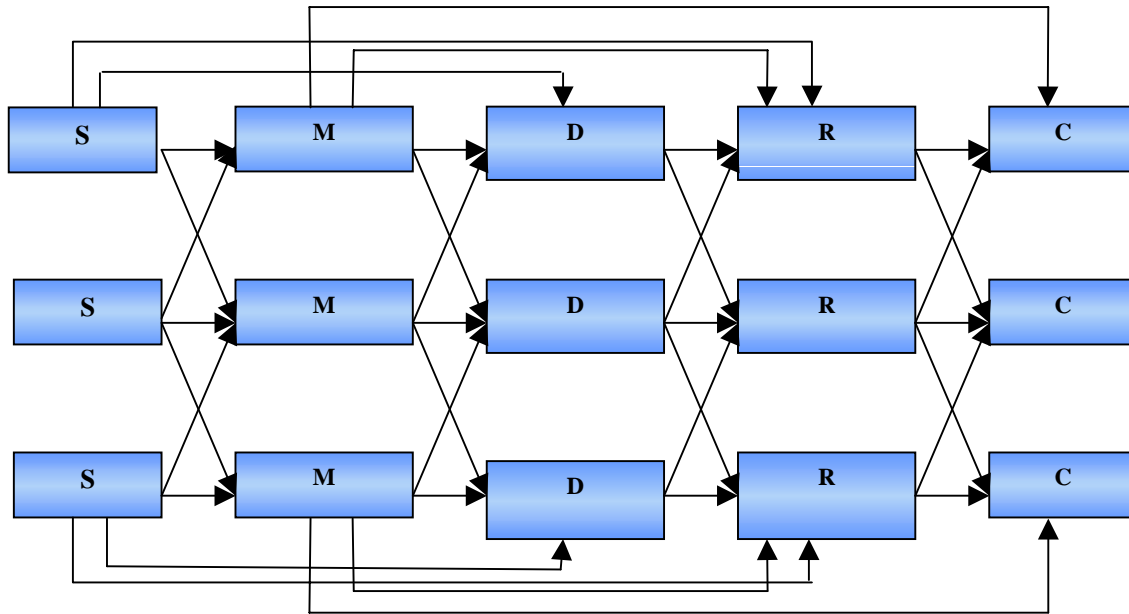

Fig. no. 1. The structure of a logistic network

While it is clear why individual organizations can benefit from knowledge sharing within the network during exploration and exploitation, it is less obvious why they should be willing to share their own knowledge. While all the network members would collectively fare best if everybody shared their knowledge, individually they can fare best if they manage to appropriate their partners' knowledge without contributing their own. If all partners follow this opportunistic behaviour, the network will never be able to achieve its economic and learning goals, which causes a social dilemma for all knowledge generating processes. However, exploration and exploitation need different solutions to this dilemma: during exploitation, strategic solutions are sufficient, but during exploration, motivational solutions have to be applied. In both situations, coordination and trust building mechanisms for logistic networks may prove to be useful.

Within logistic networks, the lack of coordination occurs either because the member organizations have objectives that conflict or because information moving between stages is delayed and distorted. The distortion due to the fact that complete information is not shared between stages is exaggerated by the fact that logistic networks today produce a large amount of product variety and innovation.

Any factor that leads to either local optimization by different stages of the logistic network or an increase in information delay, distortion and variability within the network is an obstacle to coordination. If the managers of the member organizations are able to identify the key obstacles, they can take suitable actions to help achieve coordination. These major obstacles can be divided into five categories:

- Incentive obstacles (such as focusing incentives only on the local impact of an action – that is, at the level of a single stage or organization within the logistic network)

- Information-processing obstacles (such as basing demand forecasts exclusively on the received orders, which magnifies any variability in customer demand as orders move towards the suppliers)
- Operational obstacles (such as ordering in large lots, large replenishment lead times, rationing and shortage gaming)
- Pricing obstacles (such as lot size-based quantity discounts and price fluctuations)
- Behavioral obstacles (due to the fact that each stage of the logistic network has limited visibility, being unable to see the impact of its actions on the other stages; this means that most stages of the network are unable to learn from their actions over time because the most important consequences occur elsewhere within the network).

Once the obstacles to coordination are identified, it is time to focus on the managerial levers to achieve coordination:

- Aligning of goal and incentives
- Improving information accuracy (such as sharing point-of-sale data, implementing collaborative forecasting and planning, sharing information regarding new product development)
- Improving operational performance
- Designing pricing strategies to stabilize orders
- Building partnership and trust

While the first four managerial levers shown above are action-oriented, the fifth is a relationship-oriented lever, and therefore, the most difficult to achieve.

Historically, relationships between organizations engaged in networks have been based on either power or trust. In a power-based relationship, the stronger party dictates its view. Although exploiting power may prove advantageous in the short term, its negative consequences are felt in the long term because it usually results in one member organization maximizing its profits at the expense of the others, which makes the latter permanently seek ways to resist, wasting valuable time and resources. The global profitability of the network significantly decreases when its members compete with each other rather than cooperate.

Although everybody agrees that cooperation and trust in a logistic network are valuable, these qualities are very hard to initiate and sustain. There are two views regarding how cooperation and trust can be built into any network relationship:

- The deterrence-based view (the parties involved use a variety of formal contracts to ensure cooperation)
- The process-based view (trust and cooperation are built over time as a result of a series of interactions between the parties involved; positive interaction strengthens the belief in the cooperation of the other party)

In most practical situations, neither view holds exclusively. It is impossible to design a contract that will take into account every contingency that may arise in the future, which means that parties that not yet trust each other have to rely on the building of trust to resolve issues that are not included in the contract. Conversely, parties that trust each other and have a long relationship still rely on contracts. In most effective partnerships, a combination of the two approaches is used. From the logistic network perspective, the ideal goal is co-identification, in which each party considers the other party's objective as its own. Co-identification ensures that each member of the network accounts for global network benefit when making decisions.

There are two phases to any long-term network relationship: in the design phase, ground rules are established and the relationship is initiated; in the management phase, interactions based on the ground rules occur and the relationship as well as the ground rules evolve. Careful consideration regarding how cooperation and trust can be encouraged during both phases of the relationship is very important, because in most networks, power tends to be concentrated in

relatively few hands. The concentration of power often leads managers to ignore the effort required to build trust and cooperation, hurting network performance in the long term.

The key steps in designing effective logistic network partnerships are as follows:

1. *Assesing the value of the relationship.* This means to clearly identify the mutual benefit that the relationship provides, as well as the criteria used for evaluating the relationship and the contribution of each party. Equity, defined as fair dealing, is the key principle during this step.
2. *Identifying operational roles and decision rights for each party.* The allocation of tasks results in a sequential interdependence if the activities of one partner precede the other. In order to optimize knowledge transfer, there must be a reciprocal interdependence instead, which means that parties come together and exchange information and inputs in both directions.
3. *Creating effective contracts.* Trust can be promoted by creating contracts that encourage negotiation as unplanned contingencies arise.
4. *Designing effective conflict resolution mechanisms.* An initial formal specification of rules and guidelines for financial procedures and technological transactions can help build trust between partners and avoid many conflicts. These rules and guidelines facilitate the sharing of information and knowledge among the partners in the logistic network, and over time, this helps move the relationship from deterrence-based trust to process-based trust.

Once the partnership has been designed and established, all partners learn about the environment in which the partnership will operate, the tasks and processes to be performed by each partner, the skills required and available on each side, and the emerging goals of each side. At this stage, a better evaluation of the value of the partnership becomes available, which provides all parties involved an opportunity to revise the conditions of the partnership to improve profitability, fairness and innovation capacity.

In order to achieve an effective network relationship, there are a few aspects that must be taken into consideration:

- Good organizational arrangements, especially for information sharing and conflict resolution, improve chances of succes.
- Mechanisms that make the actions of each party and resulting outcomes visible help avoid conflicts, reduce disputes and eliminate opportunistic behaviour.
- The more fairly the stronger partner treats the weaker, vulnerable partner, the stronger the network relationship tends to be.

The issue of fairness is extremely important in the logistic network context because most relationships involve parties with unequal power. Unanticipated situations that hurt one party more than the other often arise. It is thus important that the weaker party perceive the fairness of the stronger party's procedures and policies for dealing with its partners. Fair procedures should encourage two-way communication between the partners and transparency in all decisions, directly influencing the strenght and the success of the relationship in the future.

References:

1. Cabrera, A.; Cabrera E.F. – *Knowledge Sharing Dilemmas*, Organization Studies, 2002;
2. Chopra, Sunil; Meindl, Peter – *Supply Chain Managment: Strategy, Planning and Operation*, 3rd ed., Pearson Prentice Hall, 2007;
3. Handfield, Robert B., Nichols, Ernest - *Supply Chain Redisign: Transforming Supply Chains into Integrated Value Systems*, Financial Times Press, 2002;
4. Osterloh, Margit; Weibel, Antoinette – *Social Dilemmas in Explorative Knowledge Work*, 2004;